



VACUUM VALVES AND BACKFLOW PREVENTION

THE TRUSTED LINK
SINCE 1921

Safe drinking water

Water is our most essential commodity and has to be protected from contaminants. The food safety laws put stringent demands on water quality, water supply plants and networks. One particularly sensitive part of the supply network is water installations in buildings, when the water first becomes available to the consumer. It is here that the water quality could be affected. Drinking water in a pipe system has to be protected from contaminants in the same way as other foodstuffs. One major risk is the backflow of contaminated water that could spread to other tapping points and buildings. It is therefore crucial that measures are taken to prevent backflow. The installation of fittings and appliances on drinking water pipes must be carried out correctly and with suitable protective devices to avoid contaminated water from entering the pipe system and contaminating the drinking water.

Backflow

The pressure in a water pipe is not constant but ever-changing. Siphonage backflow could be caused by large draw-offs somewhere in the system, broken pipes or a line being shut off and drained. Pressure backflow can occur if the pressure downstream of the tapping point is greater than in the supply network. This could easily happen in the home when washing the car or watering the lawn as well as in workshops, factories and laboratories.

The European standard EN 1717, "Water Supply – Protection against the contamination of drinking water – General requirements for safety devices to prevent contamination by backflow" deals with backflow protection installations. The standard specifies the types of backflow prevention to use in a given situation. The standard covers various types of backflow prevention, called 'protection units', each adapted to protect different pressure ratios and fluid categories, depending on the degree of contamination. The protection units are denoted by a letter combination, EB, HB or LB, for example.

Applications

Durgo has a wide range of backflow preventers, several of which fulfil the backflow requirements as specified in EN 1717. The range includes vertical and horizontal vacuum valves of the high pressure type, with or without a check-valve, which can be used to prevent syphon backflow up to and including category 3 fluid. Durgo also has traditional horizontal and vertical terminal vacuum valves which can be used as backflow preventers and also to guard against the imploding of pressure tanks, etc. The vacuum valves are of the high pressure type, which means they can be mounted straight on to the hot and cold water pipes up to pressure level 1.0 MPa.

Material and design

Durgo's backflow preventers and vacuum valves are designed to withstand stress and strain, and protect the system for several years. The vacuum valves are made from dezincification-resistant and non-corrosive brass and are equipped with an O-ring of FKM (fluorinated rubber) to withstand high pressure and high temperatures. The valve cone is made from brass with a coating of Teflon® (PTFE) to minimise adhesion and improve reliability. In our backflow preventers with a built-in check-valve, the check-valve is of the EB type in compliance with EN 1717. The check-valve is made from POM (polyoxymethylene), also known as acetal, and has FKM (fluorinated rubber) seals and stainless steel springs. Some vacuum valve models are also available in stainless steel.

Mounting instructions

The backflow prevention is fitted straight on to the water pipe minimum 250 or 300 mm above the highest possible water level depending on the type of valve. To achieve a sufficient height, an "expansion loop" may be necessary (see fig).

Backflow preventers and vacuum valves should be installed to avoid damage to the building in the event of leakage. A funnel could be installed if necessary.

Maximum working pressure: 1.0 MPa

Maximum temperature: 125°C

Fig. 1

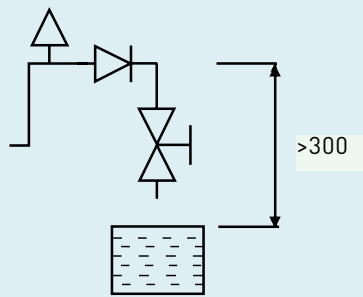

Separate vacuum valve

Fig. 2

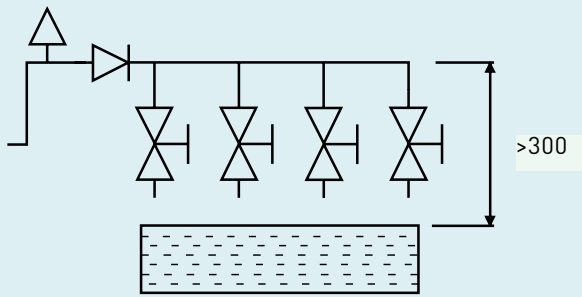

Joint vacuum valve for several tapping points

Testing and approval

Each Durgo vacuum valve is tested individually prior to delivery, both at high and low pressure. Durgo vacuum valves comply with applicable European standards.

Backflow preventers as categorised in EN 1717

Durgo VV-HF (81310) Vacuum valve type LA

Horizontal vacuum valve, flow-through model. Made from dezincification-resistant brass. Sealing of Viton® (fluorinated rubber) and a metal cone coated with non-stick Teflon® (PTFE). Male and female threads.

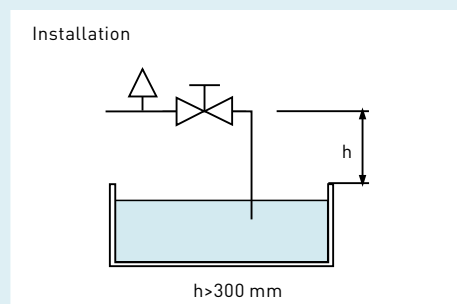

Thread	Part No.	RSK No.
15	VV-HF-G15/R15	818 68 68
20	VV-HF-G20/R20	818 68 76
25*	VV-HF-G25/R25	818 68 77

* Non chromed

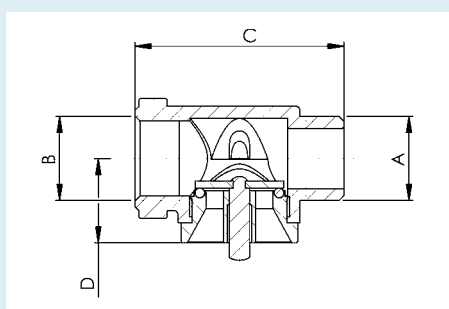

Thread	A	B	C	D
15	G 1/2	G 1/2	55	21
20	G 3/4	G 3/4	76	35
25	G 1	G 1	96	38

Durgo VV-HFB (81310 BV) Vacuum valve type LB

Horizontal vacuum valve with check-valve, flow-through model. Made from dezincification-resistant brass, also available in stainless steel. Sealing of Viton® (fluorinated rubber) and a metal cone coated with non-stick Teflon® (PTFE). Male and female threads.

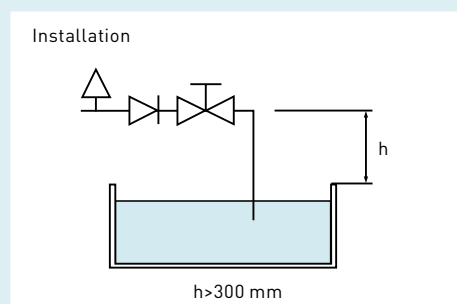

Thread	Part No.	RSK No.
15	VV-HFB-G15/R15	818 68 73
20	VV-HFB-G20/R20	818 68 74
25*	VV-HFB-G25/R25	818 68 75

* Non chromed

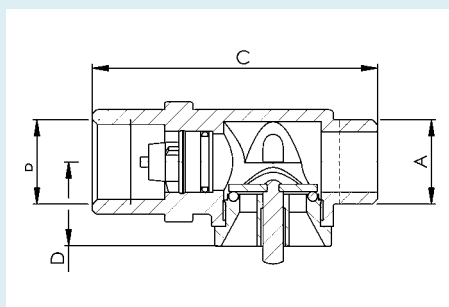

Thread	A	B	C	D
15	G 1/2	G 1/2	71	21
20	G 3/4	G 3/4	87	35
25	G 1	G 1	111	38

Durgo VV-VF (81312)

Vacuum valve type HB (Hose union anti-vacuum valve)

Vertical vacuum valve, flow-through model. Made from dezincification-resistant brass. Sealing of Viton® (fluorinated rubber) and a metal cone coated with non-stick Teflon® (PTFE). Male and female threads.



Thread	Part No.	RSK No.
15	VV-VF-R15/G15	818 68 27
20	VV-VF-R20/G20	502 13 24
25	VV-VF-R25/G25	502 13 32

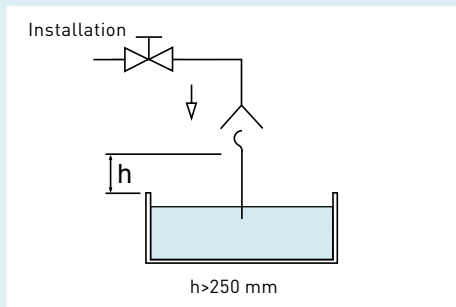
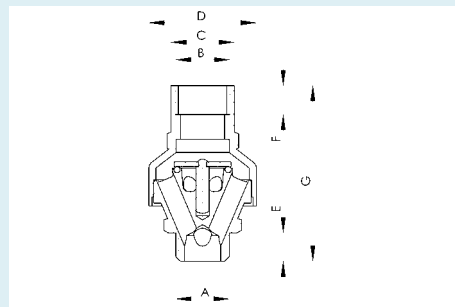

Thread	A	B	C	D	E	F	G
15	G 1/2	G 1/2	24	41	11	11	55
20	G 3/4	G 3/4	31	56	14	14	82
25	G 1	G 1	40	64	15	15	90

Durgo VV-VFB (81312 BV)

Vacuum valve type HD (Hose union anti-vacuum valve with check-valve)

Vertical vacuum valve, flow-through model. Made from dezincification-resistant brass. Sealing of Viton® (fluorinated rubber) and a metal cone coated with non-stick Teflon® (PTFE). Male and female threads.



Thread	Part No.	
15	VV-VFB-R15/G15	
20	VV-VFB-R20/G20	
25	VV-VFB-R25/G25	

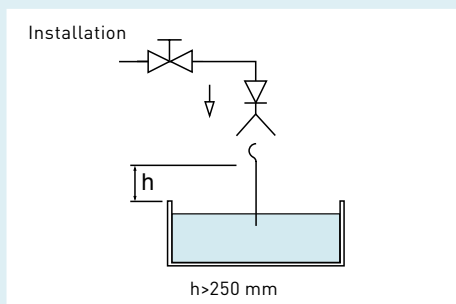
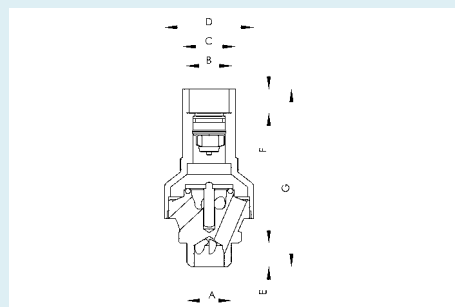

Thread	A	B	C	D	E	F	G
15	G 1/2	G 1/2	24	41	11	11	80
20	G 3/4	G 3/4	31	56	14	14	102
25	G 1	G 1	40	64	15	15	115

Backflow preventers of terminal model

Durgo VV-HT (4139)

Horizontal vacuum valve, terminal model. Made from dezincification-resistant brass. Sealing of Viton® (fluorinated rubber) and a metal cone coated with non-stick Teflon® (PTFE). Male thread.



Thread	Part No.	RSK No.
15	VV-HT-G15	818 68 35
20	VV-HT-G20	502 11 26
25	VV-HT-G25	502 11 34
32	VV-HT-G32	502 11 42
40	VV-HT-G40	502 11 59
50	VV-HT-G50	502 11 67

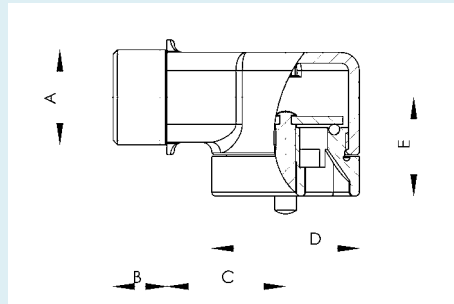
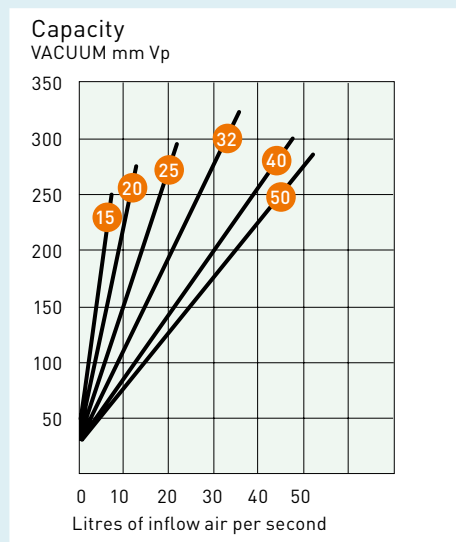

Thread	A	B	C	D	E
15	G 1/2	G 1/2	71	21	21
20	G 3/4	G 3/4	87	35	35
25	G 1	G 1	111	38	38
32	G 1 1/4	17	34	46	30
40	G 1 1/2	19	38	56	30
50	G 2	21	43	61	34

Durgo VV-VT (4140)

Vertical vacuum valve, terminal model. Made from dezincification-resistant brass. Sealing of Viton® (fluorinated rubber) and a metal cone coated with non-stick Teflon® (PTFE). Male thread.

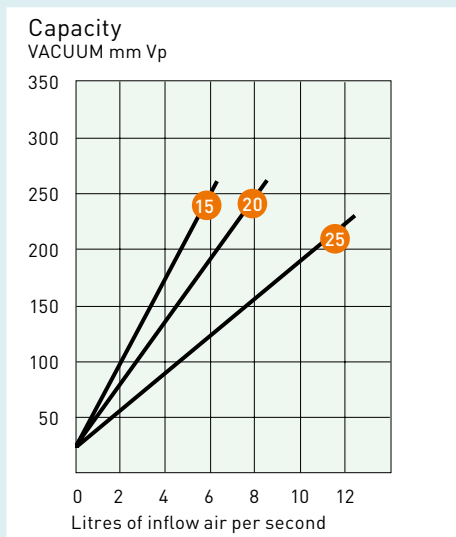

Thread	Part No.	RSK No.
15	VV-VT-G15	502 10 19
20	VV-VT-G20	502 10 27
25	VV-VT-G25	502 10 35

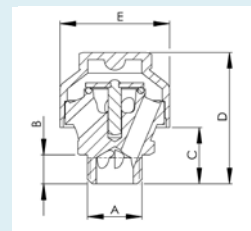

Thread	A	B	C	D	E
15	G 1/2	11	20	48	41.5
20	G 3/4	13	30	67	56
25	G 1	15	35	78	64

BACKFLOW PREVENTERS OF TERMINAL MODEL

Durgo VV-VTU (81316)

Vertical vacuum valve, terminal clamp model. Made from dezincification-resistant brass. Sealing of Viton® (fluorinated rubber) and a metal cone coated with non-stick Teflon® (PTFE). Male thread.

Thread	Part No.	RSK No.
15	VV-VTU-G15	818 68 43

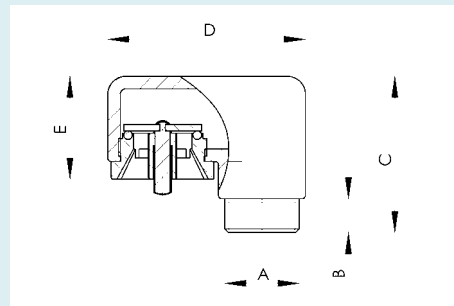
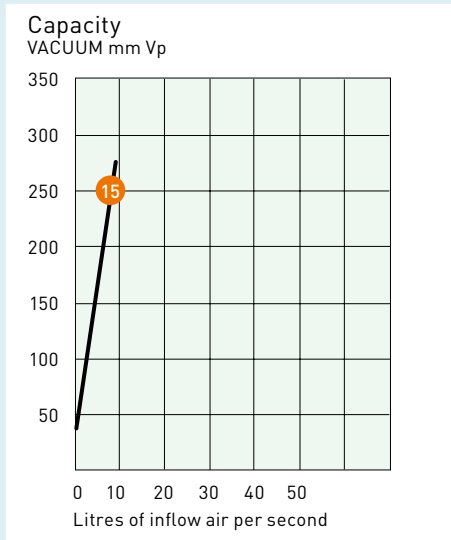

Thread	A	B	C	D	E
15	G 1/2	10	45	56	30



DURGO

THE TRUSTED LINK

SINCE 1921

DURGO – TOP QUALITY RIGHT DOWN TO THE FINEST DETAIL

Because Durgo's products are vital parts of a larger system, we always strive to be the strongest link in the chain. As we have done since 1921. Our craftsmanship tradition is close to our hearts, but only in combination with modern technology can we guarantee compliance with the highest demands on safety and quality. That is the secret behind the renowned Durgo quality.

DURGO AB
BOX 3021, SE-169 03 SOLNA, SWEDEN
RÅSUNDAVÄGEN 25, SE-169 67 SOLNA, SWEDEN
PHONE +46 8 730 5280, FAX +46 8 735 6955
SALES@DURGO.SE
WWW.DURGO.SE